

TECHNICAL DATA

SINGLE DRUM ROLLERS

BW 211 D-40, BW 211 PD-40

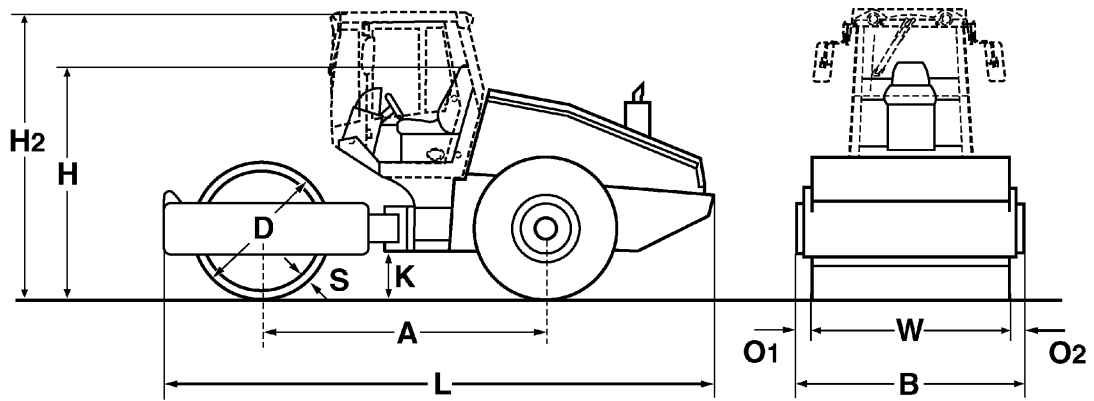



Dimensions in mm

	A	B	D	H	H2	K	L	O1	O2	S	W
BW 211 D-40	2960	2250	1500	2268	2985	490	5840	60	60	25	2130
BW 211 PD-40	2960	2250	1480	2268	2985	490	5840	60	60	25	2130

Shipping dimensions in m3

BW 211 D-40
BW 211 PD-40

without ROPS

29,802
 29,802

with ROPS

39,223
 39,223

Machine type	Compaction output (m3/h)			
	Rock fill	Gravel, sand	Mixed soil	Silt, clay
BW 211 D-40	400-800	270-540	220-440	110-220
BW 211 PD-40	400-800	270-540	220-440	160-320

Machine type	Compacted layer thickness (m)			
	Rock fill	Gravel, sand	Mixed soil	Silt, clay
BW 211 D-40	0,70	0,50	0,40	0,20
BW 211 PD-40	0,70	0,50	0,40	0,25

Technical Data**BOMAG
BW 211 D-40****BOMAG
BW 211 PD-40****Weights**

Grossweight	kg	13.000	12.620
Max. axle load, drum CECE	kg	8.050	7.670
Max. axle load, wheels CECE	kg	4.950	4.950
Operating weight CECE	kg	9.500	11.350
Axle load, drum CECE	kg	5.750	6.750
Axle load, wheels CECE	kg	3.750	4.600
Static linear load CECE	kg/cm	27,0	
Max. static linear load CECE	kg/cm	37,8	

Dimensions

Working width	mm	2.130	2.130
Track radius, inner	mm	3.494	3.494

Driving Characteristics

Speed (1)	km/h	0- 6,0	0- 6,0
Speed (2)	km/h	0- 10,0	0- 10,0
Max. gradeability without/with vibr.	%	45/43	49/46

Drive

Engine manufacturer		Deutz	Deutz
Type		BF4M 2012 C	BF4M 2012 C
Emission stage		Stage II / TIER2	Stage II / TIER2
Cooling		Liquid	Liquid
Number of cylinders		4	4
Performance ISO 3046	kW	98,0	98,0
Performance SAE J 1995	hp	132,0	132,0
Speed	min-1	2.300	2.300
Fuel		Diesel	Diesel
Electric equipment	V	12	12
Drive system		hydrost.	hydrost.
Drum driven		standard	standard

Drums and Tyres

Tyre size		23.1-26/12PR	23.1-26/12PR
Number of pad feet			150
Height of pad feet	mm		100
Area of one pad foot	cm ²		137

Brakes

Service brake		hydrost.	hydrost.
Parking brake		hydromec.	hydromec.

Steering

Steering system		oscil.artic.	oscil.artic.
Steering method		hydrost.	hydrost.
Steering / oscillating angle +/-	grad	35/12	35/12

Exciter system

Drive system		hydrost.	hydrost.
Frequency	Hz	30/36	30/36
Amplitude	mm	1,80/0,95	1,70/0,86
Centrifugal force	kN	236/170	275/202
Centrifugal force	t	24,1/17,3	28,1/20,6

Capacities

Fuel	l	250,0	250,0
------------	---	-------	-------

Technical modifications reserved. Machines may be shown with options.

Standard Equipment

- Warning, information and operation displays with round gauge
- Hydrostatic travel and vibration drive
- Hydrostatic articulated steering
- Articulated joint lock
- Rear axle with twin spring accumulator brakes
- Self locking differential
- Warning horn
- Single lever control for travel and vibration
- Scrapers
- Emergency STOP
- Back-up warning system
- Operator seat
- Maintenance-free articulated joint

Optional Equipment

- Cabin with air conditioning
- ROPS/FOPS cabin with seat belts
- Working lights front / rear
- ROPS/FOPS with safety belt
- Rotary beacon
- Padfoot segment kit (D)
- Contact scrapers (2x)
- ECONOMIZER
- BOMAG Evib-Meter (BEM)
- Special painting
- Air condition
- Ballast front (700kg)
- Sun roof
- Radio (Bluetooth)
- BOMAP
- Indicator and hazard lights

