

CityCat **V20e**

Vehicle description



Index

1	Technical data and description of CityCat V20e	2
2	Vehicle Overview	3
3	Dimensions	4
	Vehicle dimensions	4
	Turning circle & sweeping width	5
4	High capacity Bucher Battery Pack BBP-63	6
5	Chassis & Axles	7
6	Drive train	8
7	Brakes	9
	Service brake	9
	Parking brake	9
8	Tyres & Rims	9
9	Hydraulic	10
10	Electrical system	11
	Lighting	11
11	Steering	12
	Articulated steering	12
	Precise tracking thanks to articulated steering:	13
12	Driver's cab	14
13	Instrumentation & HMI	16
14	Sweep system	18
	Overview	18
	Dirt pick up system - brushes and suction intake	19
	Hopper	21
	Water system	22
15	Disclaimer	24

1 Technical data and description of CityCat V20e

Introduction



The CityCat V20e is the result of many years of experience in the design, development and production of compact sweepers for professional use. The sweeper has been developed in close cooperation with the users to meet all their needs such as: excellent all-round visibility, safe use through simple operation and sophisticated design. Reliability and efficiency thanks to the use of high-quality materials and components. Easy to maintain thanks to the well-thought-out design. Environmentally friendly thanks to the Li-ion battery drive and the resulting advantages in terms of pollution and noise. And these are just some of the outstanding features.

The CityCat V20e is a highly specialised, high performing articulated sweeper that meets all the requirements of private cleaning companies and municipal service providers who want to offer an efficient and costeffective cleaning service.

2 Vehicle Overview

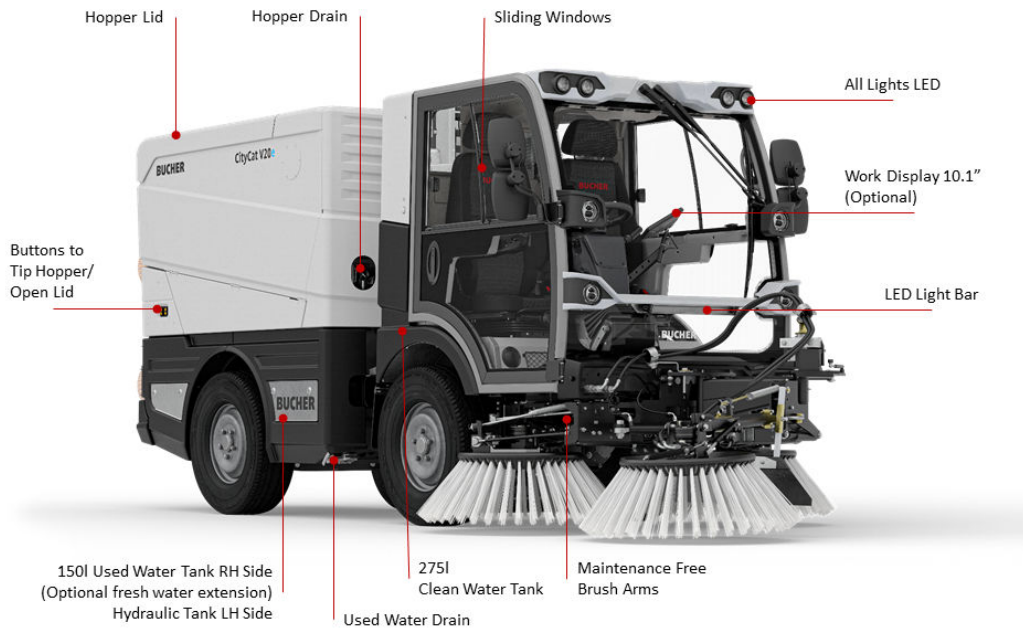

3 Dimensions

Vehicle dimensions

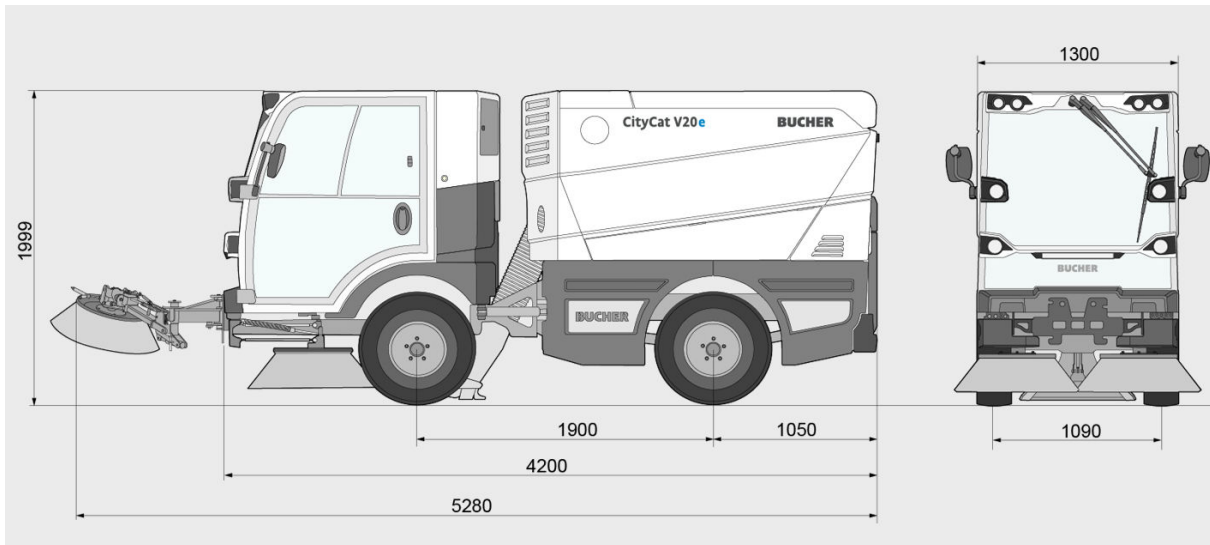

Dimensions

Length	4200 mm
Width	1300 mm
Height	1999 mm
Wheelbase	1900 mm
Track width	1090 mm
Cleaning width	2100 mm
Cleaning width 3rd brush	2700 mm

Weight

Empty weight	2700 kg
Payload	2100 kg
GVW	4800 kg

HV Battery

Battery type	Li-ion
Battery capacity	63 kWh
Nominal voltage	335 Volt
Operating time	up to 8 hours

Drive system

Working speed	0 - 15 km/h
Travelling speed	0 - 50 km/*
Climbing ability	up to 30%
Electric drive	45 kW
Electric fan	8.5 kW
Electric hydraulic aggregate	12 kW

Emissions

Noise level LWA	92 dB(A)
PM certification	PM 2.5/PM10 ****

Charging system

Internal charger	22 kW
Charger inlet	Type 2
Charging time	2 to 3 hours

Tyres

Lightweight 215/75 R16 C M+S

* According to national legislation

Turning circle & sweeping width

Turning circle kerb-to-kerb

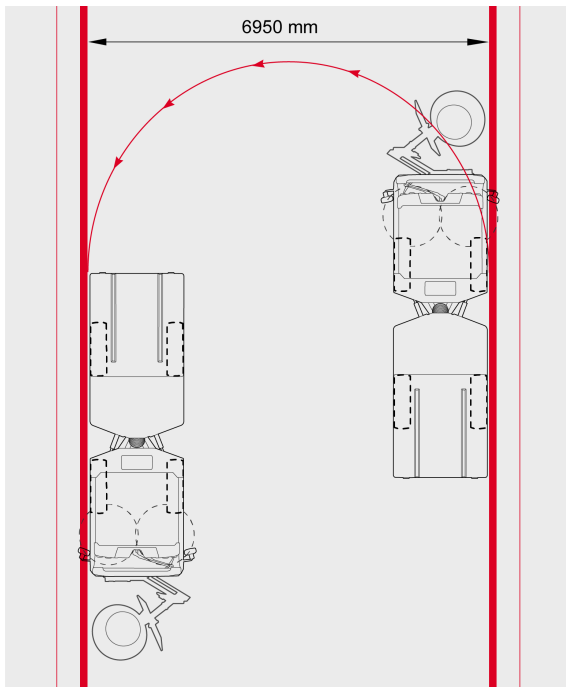

Turning circle wall-to-wall

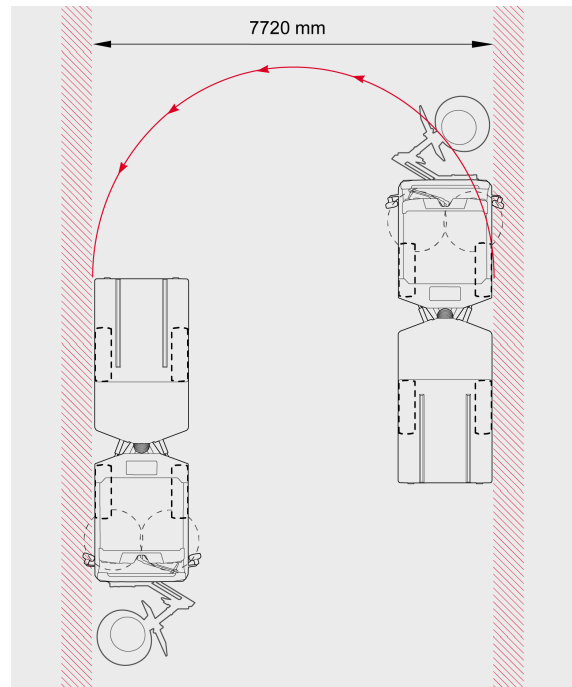

Sweeping width with 2 and 3 brushes

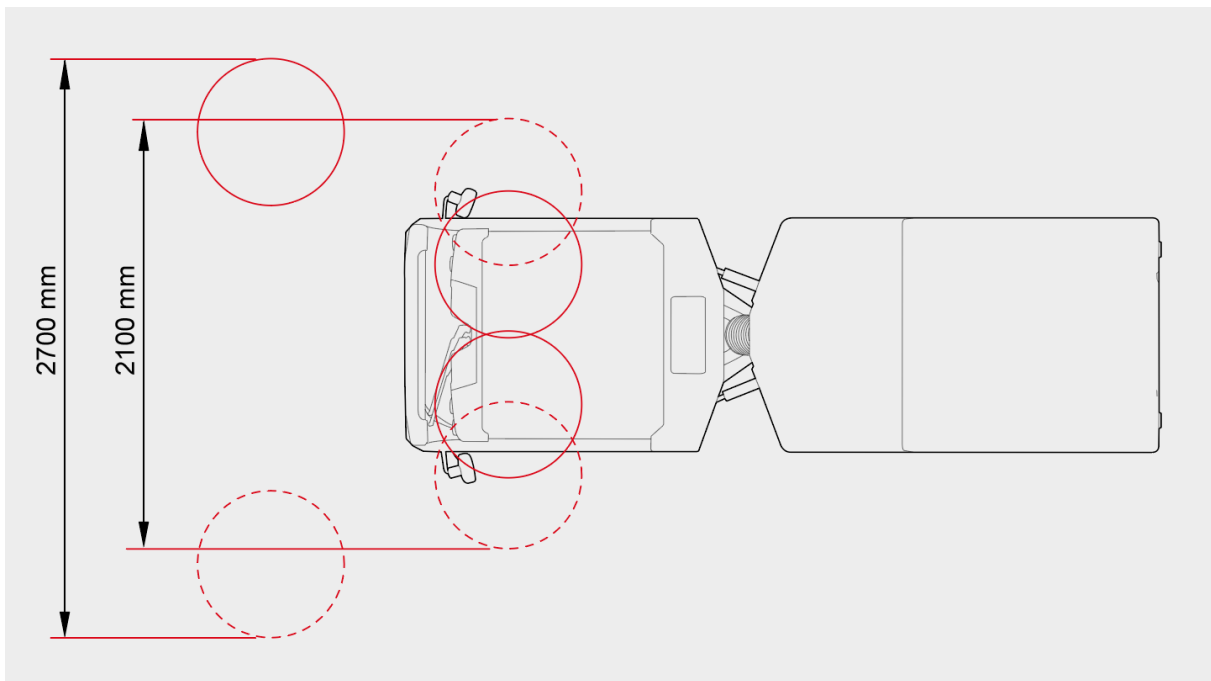

4 High capacity Bucher Battery Pack BBP-63

The electric sweeper draws its energy from a modern lithium-ion battery using prismatic automotive cells. Compared to other batteries, it provides a longer service life and a greater range. Another advantage is that lithium-ion batteries have no memory effect and have an optimized ageing behavior.

High capacity battery pack with 63 kWh guarantees an outstanding autonomy with an operating time of up to 8 hours with a single charge. The exceptionally robust and maintenance - free design provides a long service life with a minimized battery aging.

Automotive BMS (short circuit, overcharge, over discharge protection and cell balancing). Shock, water and dust proofed steel case.

HV Battery BBP-63

Battery capacity	63 kWh
Nominal voltage	335 Volt
Capacity	188 Ah
Temperatur range	- 10 to + 40 °C
Charging cycles	up to 6000*

BBP-63 Module

Lightweight & compact
Robust against shock and vibration
Maintenance free
High current charge & discharge
UN38.3 certified

BBP-63 Cell

Automotive prismatic cells
Li-Ion NMC chemistry
Superior life time (cyclic and calendrical)
High current charge & discharge
Big operating temperature range

BBP-63 System

Temperature control
Integrated active Insulation monitoring
Fully sealed IP69K battery housing
Designed acc. UN Regulation No. 100 -Rev.2 -
Electric power trained vehicles
Sophisticated repair concept for maximum safety
(Patent in preparation)

*Depending on the charging profile

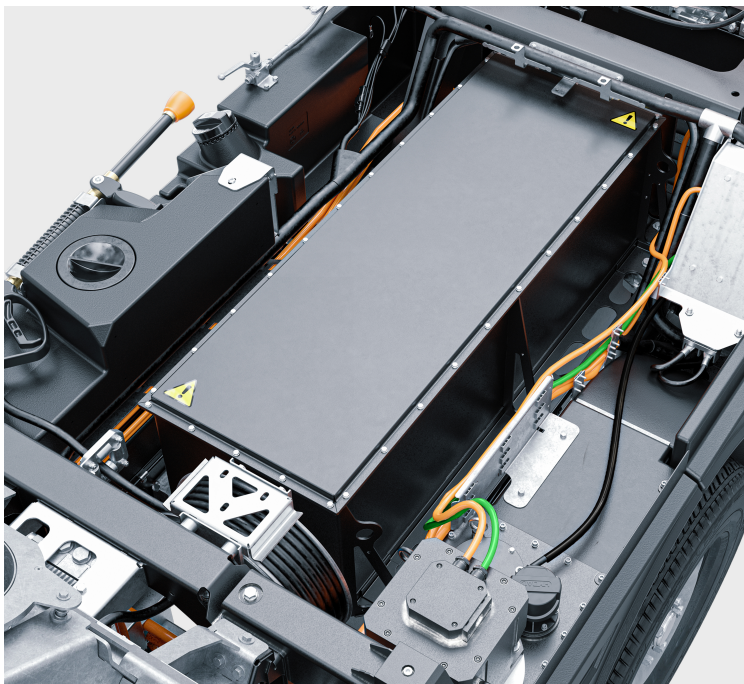

5 Chassis & Axles

Two-part ladder-type frame chassis with "C" profile construction. 6 mm thick steel, all welded construction. The rigid chassis contributes to a better drive stability as the rear and the front wagon cannot twist to each other. This is an advantage when driving curves with high speed and with high loads. The joint of the articulated steering has no lubrication points and is therefore almost maintenance free which leads to low TCO's.

Bucher designed single wheel coil spring suspension on front axle

- Lightweight
- Increases driving comfort
- Crucial for a stable and safe riding behaviour
- Maintenance-free

Rear axle with heavy duty leaf springs and shock absorbers.

- Reliability
- Low maintenance

Weight		Front Axle		Rear Axle	
Unladen weight	2700 kg	Unladen	1130 kg*	Unladen	1570 kg*
Payload	2100 kg	Loaded	1992 kg	Loaded	2804 kg
GVW	4800 kg	Allowed	2200 kg	Allowed	3000 kg

*calculated without options

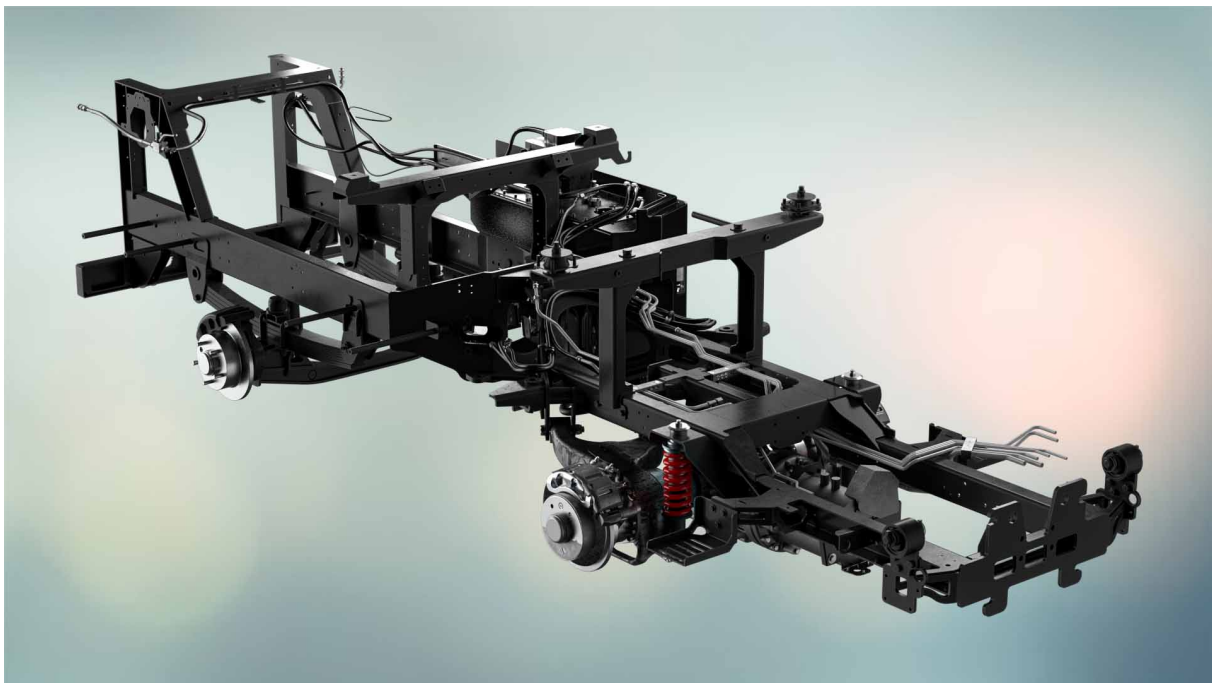

6 Drive train

Driven front axle with electrical engine, flanged to the self-locking differential gearbox (Torsen differential gear).

The differential begins to send more torque to the slower-rotating wheel the instant there is a speed difference between them to ensure maximum traction.

Possible to change between driving mode and working mode without stopping the vehicle for a time-saving, simple and intuitive operation.

Zero-Speed-Holder with permanently energized synchronous motor with high torque allowing full climbing ability up to 30% and automatic holding on the hill when stopping the vehicle.

Infinitely variable speed control from 0 to 50 km/h (model-specific) in road travel mode for short transport times from station to place of action.

Drive System

Working speed	0–15 km/h
Travelling speed	0–50 km/h
Climbing ability	up to 30%

Engine

Brand	Bosch
Type	SMG180
Nominal power	45 kW
Energy recuperation	up to 20%



7 Brakes

Service brake

The service brake is hydraulically actuated via a foot pedal. Dual-circuit DOT braking system, hydraulic supplied with disc brakes (double callipers on each side) on the front and rear axle.

Manually operated parking brake, acting hydraulically on additional brake disc ahead of differential.

Advantages of disc brakes

- Better cooling performance
- Cooling is far more rapid which makes them better suited for high-performance driving or heavy-duty vehicles and reduces the likelihood of brake fade
- After being driven through water, disc brakes operate at peak performance almost immediately
- Disc brakes are self-adjusting and do not need periodic maintenance
- Disc brakes are also easier to service than drum brakes

Parking brake

Manually operated parking brake, which acts hydraulically on the additional brake disc in gearbox.

8 Tyres & Rims

Front axle

Tyres 215 / 75 R16C M+S
Rims 6Jx16 ET50

Rear axle

Tyres 215 / 75 R16C M+S
Rims 6Jx16 ET50

Large tyres provide better springing, quieter running and improved climbing capability when negotiating obstacles.

9 Hydraulic

The volume flows and working pressures are adjusted electronically as required. This control ensures that the system works efficiently at all times and the energy consumption is kept low.

The consistent piping of the system reduces the proportion of hydraulic hoses and thus reduces maintenance and repairs.

A heat exchanger in the hydraulic tank is connected to the coolant circuit and ensures an optimum operating temperature.

The Bucher hydraulic power unit with water cooled Inverter Sevcon HVLP-20 is driven by an electric motor 6.87 kW, (peak: 12 kW) 32.8 Nm, 2000 r/min. It has a low-noise Bosch Rexroth dual pump system.

The two pumps supply the attachments and movement cylinders with oil (the Fan is powered by an electric motor):

1st Bosch Rexroth Gear pump

Model: AZPJJ-22-014, 14 cm³, max. 28 l/min, max. 110 bar

In first priority the pump supplies the brake assist, in second priority the optional front brush motor and the optional high-pressure water pump.

2nd Bosch Rexroth Gear pump

Model: AZPJJ-22-012, 12 cm³, max. 24 l/min, max. 160 bar.

In first priority the pump supplies the steering system, in second priority the side brush motors and cylinders for linear movements.

Hydraulic oil: HLP 46

Reservoir capacity: approx. 50 l.

Filtration: Return flow filter Hydac type 75 R, 10 η m

10 Electrical system

Wiring, fully shielded for water protection, colour coded and fuse protected.

Electrical system

Voltage	12 V
Battery	95 Ah
Climbing ability	up to 30%
Alternator output	110 A

Lighting

All Lights are low-consumption LED Lights. Four headlights arranged on different levels on the front of the cabin. Big Lightbar to illuminate the work area right in front of the cab. Four work lights mounted at the very top of the front of the cab to illuminate the whole work area in front of the sweeper. Side brush work lights which illuminate the work area on the left and right hand side of the cabin. Two rear lights with optional fog light (one fog light). Top mounted LED rotating beacons, one on the cab (retractable), one at the rear of the hopper (foldable).



11 Steering

Articulated steering

Hydrostatic controlled articulated steering for precise manoeuvrability.

The steering hydraulic flow is of the load-sensing type, i.e. it is first supplied with oil when activated and then with an upstream priority valve.

Overlap in curves

Thanks to the articulated steering, the front brushes and suction intake follow the direction of travel; No dirty streaks or smears left behind.

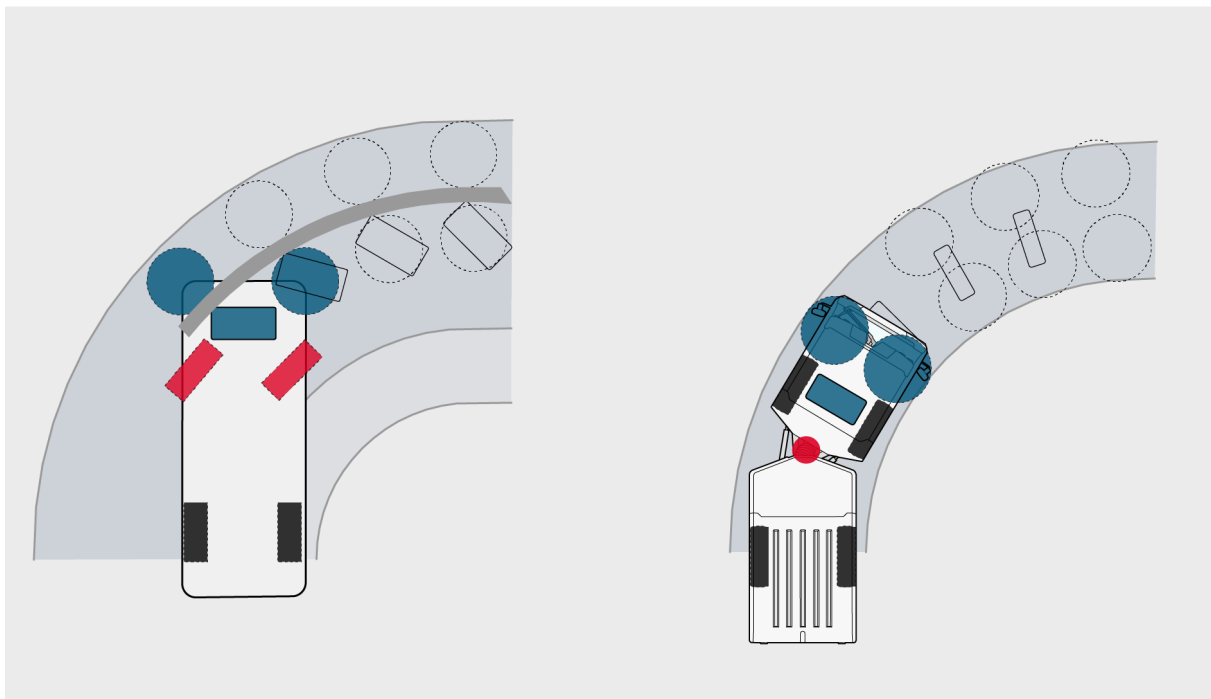

Front steering:

With front steering, the brushes and the suction intake are moved to the side

This can lead to waste and dirt strips being left behind.

Articulated steering:

The brushes and the suction intake automatically follow the track of steering movements

No waste and dirt strips being left behind.

Precise tracking thanks to articulated steering:

The rear part of the vehicle follows the exact track of the front part.
Comparison of steering systems with the same washing track:

Front steering: Vehicle cuts the corners

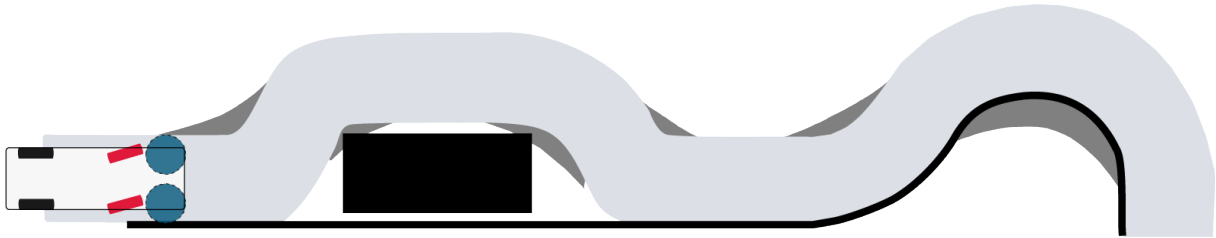

Rear steering: Rear of vehicle swings out

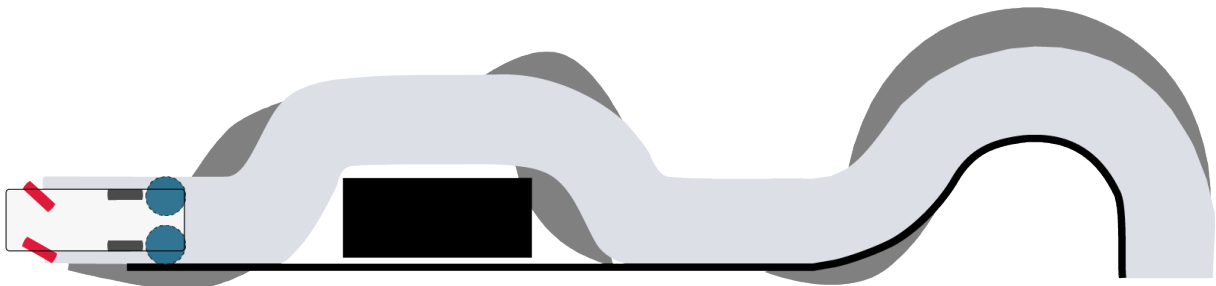

Four-wheel steering: Vehicle slightly cuts the corners

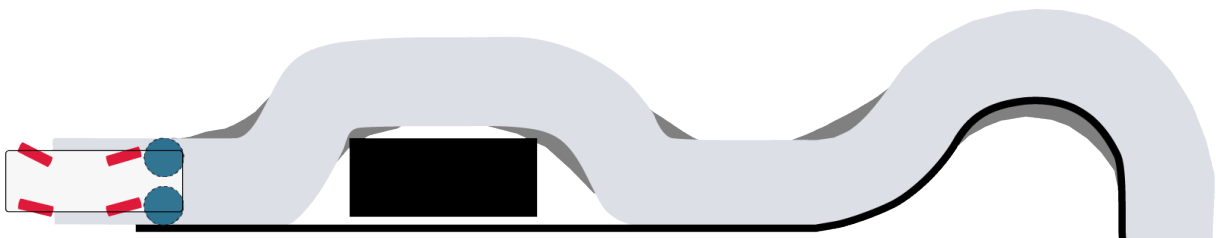

Articulated steering: Vehicle follows the cleaning track precisely

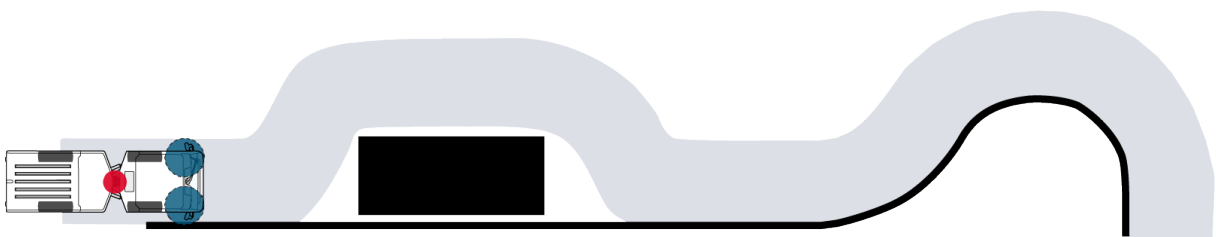

12 Driver's cab

The aluminium cab is soundproofed and mounted on modern solid rubber mountings.

Tinted safety glass on the windscreen. Low reflection, noise-deadening, curved front windscreen. Top-mounted working lights built into the bodywork (option).

Two fully fledged seats with adjustable back rest and adjustable lumbar support. The backrest is fully foldable for ease of access behind the seats. The passenger seat equipped with the optional head rest and both seats equipped with the optional 3-point safety belts provide for a safe work environment. The seats have a front and backwards stroke of +/- 50 mm. Driver seat with mechanical suspension is optional also available with air suspension. All suspensions with weight adjustment possibilities.

Gas spring loaded steering column, adjustable in rake and reach, with soft touch steering wheel. Centre console with cup holder, USB charging plug, emergency stop switch, water taps for the fresh water jets and parking brake.

Multi-speed heater fan and air-conditioning with defroster nozzles from below for front and side windows as well as for footwell.

Sun visor on driver's and passenger's side, two heated exterior rear-view mirrors, two additional sweeping mirror, windscreen washer-wiper system, radio preparation (UKW, DAB+) and windscreen heating. Internal lighting. Side window opening horizontally, forwards and backwards.

Maximum safety for driver and environment (Roll-Over Protection Structure - ROPS).



12 Driver's cab

Walk through cab

Enhanced feeling of space
Unobstructed field of vision

Access to all necessary data & functions

Smart-Con 4.3" driver display with pop-up feedback
CSense 10.1" touch display (optional)

Operating concept

Smart-Con - one hand control, intuitive design
All operator tools within easy reach

Compact steering console

Adjustable in rake and reach
Soft touch steering wheel

State-of-the-art driver comfort

Ergonomically designed workspace

Smart-Con multi-functional armrest

Adjustable & tailored to the driver

Spacious cab interior

Spacious driver position
(foot room, head room, etc.)
Maximum driver comfort

Large, wide field of vision

Maximum driving safety
Optimum visibility
Excellent all-round view



13 Instrumentation & HMI

The UX-design of the software is a critical aspect for operator comfort and has been rebuilt from scratch to ensure that the operators focus lies on the important events and minimizes premature fatigue.

The Smart-Con multi-functional armrest with smart “start function” in combination with the Smart-Con digital 4.3-inch display makes it possible to operate all working functions with one hand.

All relevant information about the vehicle, such as control lamps and level indicators, can be seen on the Smart-Con digital 4.3-inch display. Feedback on the sweeping system settings through a pop-up allows for safe and ergonomic use.

Smart-Con multi-functional armrest on the right-hand side, ergonomic one-hand operation with controls for movements and speed of the entire sweeping system, operation of the spray water system, water recovery system and optional medium and high-pressure water systems, operation of the hopper movement and the shuffle button for reversing.



Easy to survey and ergonomically arranged operating and monitoring instruments. CAN bus controlled system with CSense 10.1-inch colour touch display for all operating functions, sweeping system (fan speed, operating hours, km counter etc.) saving of pre-setting's and visual diagnostic system. Both, the Smart-Con 4.3-inch and the CSense 10.1-inch display can be used for the camera system. The displayed vehicle setup can be individually chosen by the driver.



The sweeping data which can be displayed on the CSense 10.1 – inch touch display can also be optionally downloaded via the USB port in the middle console. This data includes Serial-No, Date, Time, Work - Hours, Transit - Hours, Total - Hours, Work - km, Transit - km, Total - km, Total Consumption - kWh (EV).

14 Sweep system

Overview

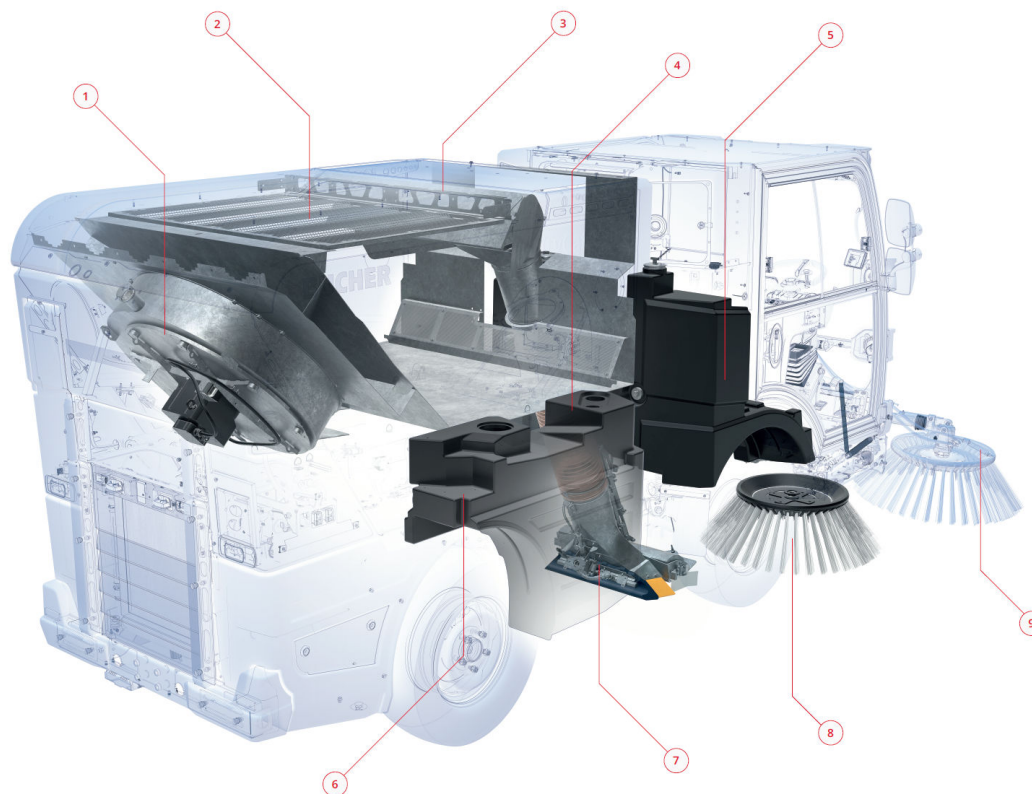

- | | | |
|--|--|--|
| 1 Optimised fan arrangement, with bigger, optimised blade wheels for greater efficiency | 5 Large 275L fresh water capacity for maximum operating times | 9 Water nozzles for maximum dust suppression |
| 2 Easy to clean mesh in hopper to prevent clogging by leaves and debris | 6 150L tank for service water (optional fresh water extension) separated from hopper for easier cleaning and low point of gravity | 10 Optimal air flow, no over-suction, minimal noise emissions |
| 3 Large 2m ³ hopper with “easy clean” option available | 7 Flow-optimised, floating suction mouth with gimbal suspension for uneven surfaces – ensures maximum air velocity for perfect sweeping results | |
| 4 Straight suction hose providing optimum air flow with minimum risk of blockage | 8 Maintenance free sweep gear. 0-120 rpm, infinitely adjustable. Overlapping of suction mouth and brush due to unique brush arm design | |

Dirt pick up system - brushes and suction intake

The side brushes on the left and right have a diameter of 800 mm and can be adjusted infinitely from 0 - 120 rpm. Brushes are suspended from a parallelogram system and are mounted so that they are drawn in the direction of travel. The parallelogram ensures tilt axle is always in the direction of travel, regardless of its lateral position.

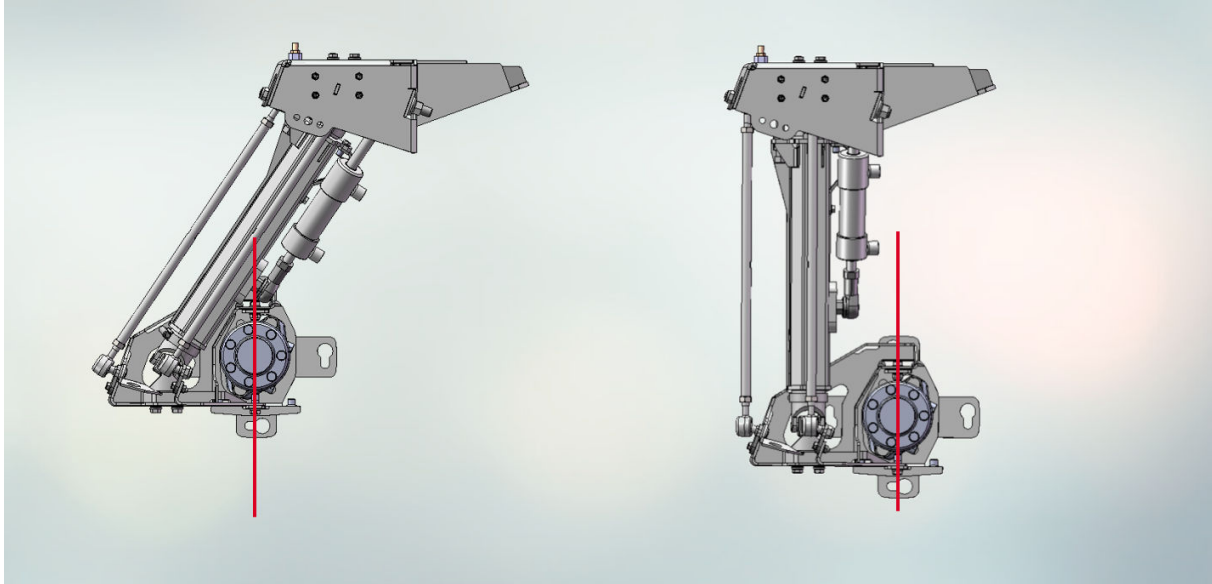

The pulled brush system is maintenance free, reducing TCO and downtime. This is achieved through completely long-life lubricated joints, sealed and protected from external influences such as dirt and water.

For the side brushes there is a wide range of options like ground pressure control, tilt adjustment and others – see option catalog for further information.

The 3rd front brush which can be used on the left and right can be hydraulically pivoted, raised and inclined. Brush diameter 800 mm, speed variable 0 – 120 rpm.

The brush has collision impact protection consisting of a Rosta suspension unit on the swivel joint and a sprung telescopic front arm.

The Combi Arm (optional) has the same functions as the front brush described above, with the only difference being that a rigid component with an additional Rosta suspension joint takes the place of the telescopic arm (front component).

This enables more power to be applied to the brush. When used in conjunction with a brush with wire bristle, it is ideal for weed removal.

The 3rd front brush is further secured with a hydraulic pressure control valve against excess load.

14 Sweep system



The City Cat V20 series is designed so the high-suction power hose is free to work harder. Just like the floating suction intake, the straight suction hose also belongs to the Bucher "DNA" and results in minimum risk of blockage and optimum air flow for trouble-free operation.

Located between the front axle, the suction intake is secured against damages due to impacts, as the intake is raised together with the wheels when driving over an obstacle. It can be raised hydraulically in stages at the push of a button. The patented hanging mechanism ensures that the suction intake adapts to changing incline and keeps the same clearance to the ground to ensure maximum air velocity for perfect sweeping result.

The leaf flap is hydraulically operable and allows a pick-up of bulky materials. The aluminium casted suction intake has a width of 650 mm (720 mm with rubber strip). The suction tube has a diameter of 200 mm.

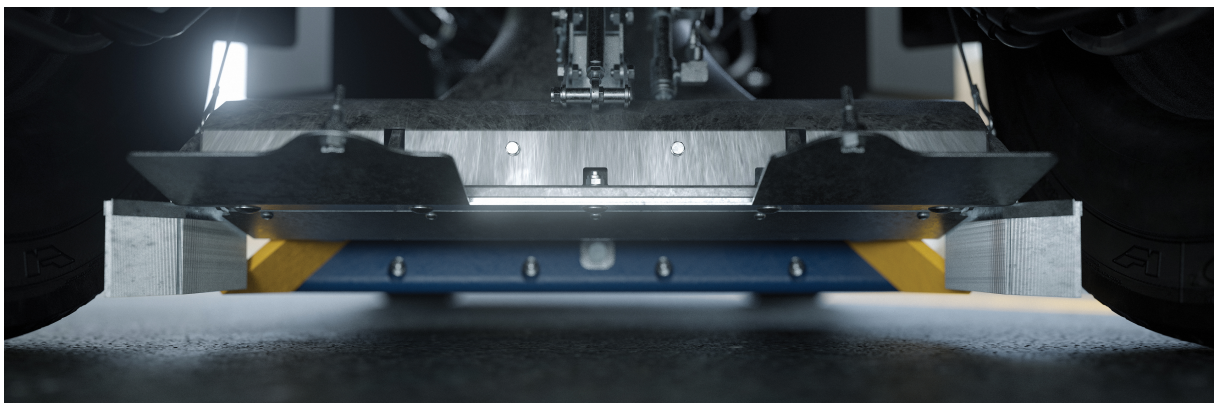

Hopper

The debris hopper has a gross volume of 2.0 m³ and a Net of 1.3 m³ and is made of 2.0 mm thick stainless steel (material number 1.4003). The high-pressure suction fan is on the back of the hopper. The large mesh area allows the dirt to be optimally released from the air flow. The mesh hinged to the hopper cover for easy cleaning. The stepless fan runs at speeds up to 2300 rpm (optional up to 2600 rpm with a maximum conveying capacity of 10'000 m³/h).

Dimension of ventilator housing:	800mm by 850mm
Diameter of ventilator:	660 mm
Height of ventilator:	75 mm
Blades:	7

The hopper can be tilted to an angle of 90° and is hydraulically secured against lowering by a non-return valve. The dumping width is 1'043 mm, the dumping height 1'555 mm. The hopper roof can be hydraulically raised from the outside of the sweeper providing access for throwing in large debris. The service water is filtered and then fed to the suction intake to ensure optimum dust suppression.



Water system

The fresh water tank has a volume of approx. 275 l, filling via Air-Gap water filling system and is made from plastic. The water tank is located under the cabin, providing a low point of gravity and therefore contributes to the driving stability.

The secondary water tank is placed under the hopper in the chassis and has a capacity of approx. 150 l. The design allows to use the secondary water tank to be used as a water extension, leading to a total of 425 l fresh water (not in combination with recirculation system). This configuration is especially useful in combination with the 20bar mid pressure water pump for a combi application sweeping / washing.

In the standard configuration, the tank is configured for the service water allowing to recycle the water an maximizing the uptime.

The service water is fed directly to the suction intake via a valve which can be controlled from the driver's seat. The water is fed by gravity meaning no pump is used which will help lower cost and time for maintenance as the recuperation water is often soiled.

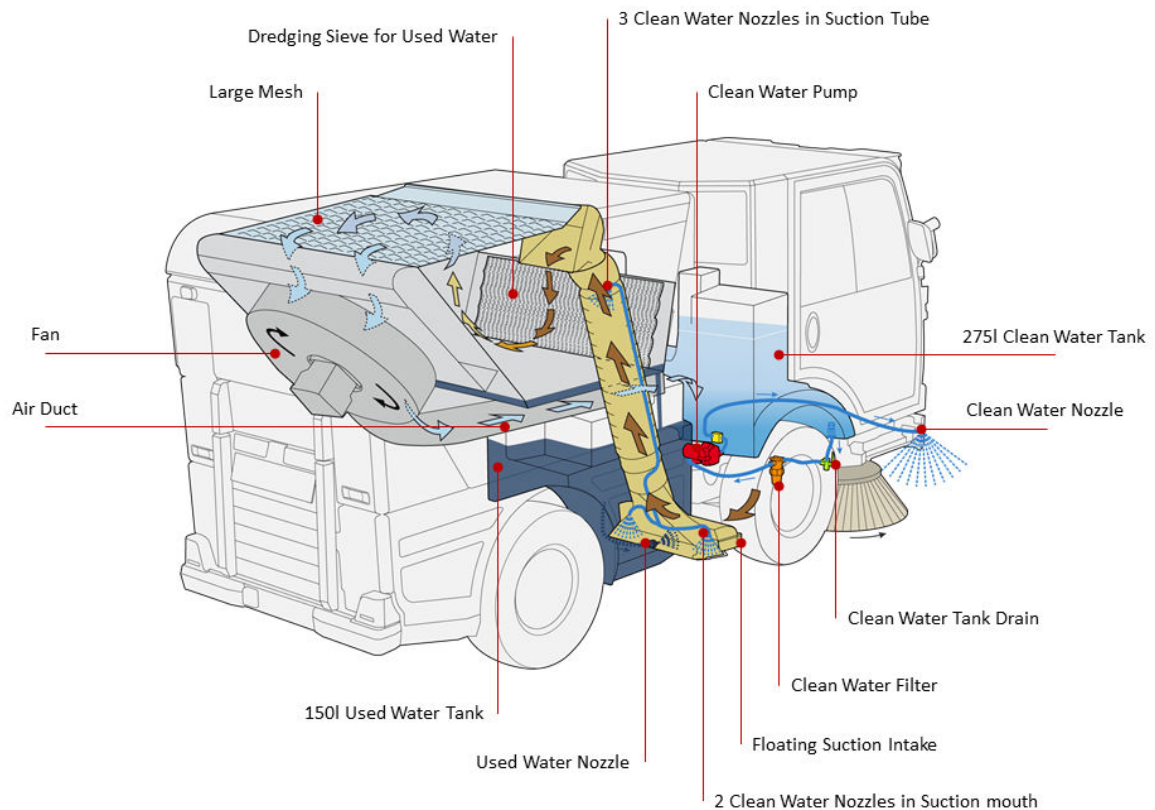

14 Sweep system

The electrical water pump, operating at 1.5 bar and 12 l/min, feeds clean water to the spray nozzles fitted to the sweeping brushes, the suction nozzle and the suction pipe.

1. 1 nozzle to each side brush
2. 2 nozzles on the suction intake
3. 3 nozzles on the suction pipe
4. 1 nozzle on the 3rd brush (if 3rd brush is assembled)



All nozzles are individually adjustable from the cab.

15 Disclaimer

Technical modifications due to product improvement are reserved

Bucher Municipal Asia

258, Seohaean-ro, Siheung-City,
Kyunggi-Do, Korea 15086
Phone: +44 7436 182927
info.asia@buchermunicipal.com

www.buchermunicipal.com



Driven by better