

# Fine concrete pump P 718 – Record-breaking technology in the smallest of spaces

From the New York skyline, to the Jin Mao Tower in Shanghai, to the skyscrapers of Dubai... For many years, Putzmeister products around the world have stood for maximum performance and absolute reliability – even under the hardest of conditions.

We are now offering for the first time this outstanding technology in a surprisingly compact and versatile fine concrete pump: the new P 718.

It is our most powerful machine of this kind to date with impressive performance data, but also lightweight with a well thought-out and user-friendly design.

The modern and dynamic design of the P 718 makes it a real eye-catcher on any construction site. However, the **high-quality hood and body** do more than simply look good. They provide many additional practical benefits that increase the service life of the P 718 and help it retain its value:

- It is very lightweight, yet extremely solid at the same time
- Plastic does not rust
- The smooth paint finish effectively prevents dirt from accumulating on surfaces and is particularly easy to clean
- The body has been coated with a high-quality cathodic dip coating
- This results in an absolutely even coat of paint that provides reliable protection against rust



Transportation to the construction site and manoeuvring on site are child's play thanks to the **roadworthy T-chassis**. On inaccessible construction sites, the P 718 can also be put into position by crane. The **solid lifting eye** fitted as standard makes it possible



The **large hopper only needs to be folded away to the side** for easy maintenance or cleaning. The agitator is then completely open and easily accessible in front of you. This will save time and effort.



You only need to press one button to open the hood. It immediately moves upwards completely by itself.



Once the hood is open, the **tidy and easily accessible engine compartment** is visible. All maintenance and service areas can be accessed quickly and conveniently from here.

The **solid support feet** provide excellent stability for your work. They are simply retracted for transport.

## Environmentally sensitive power pack – the diesel engine

The **oil-cooled 3-cylinder diesel engine** in the P 718 provides 34.5 kW. This gives you sufficient power for tackling even the most demanding jobs any time.

Despite the high performance of this modern engine, it runs at a **very low speed**. This reduces wear, makes it substantially quieter and saves on diesel. Moreover, it complies with the recent **exhaust gas regulations** and thus has a low impact on the environment.



Model	P 718 <sup>TD</sup>
Piston pump	2-cylinder, hydraulically driven
Theor. delivery rate (piston side)*	max. 17.4 m <sup>3</sup> /h
Delivery pressure (piston side)	max. 68 bar
Cylinder diameter/ piston stroke	150 mm / 700 mm
Strokes (min.)	27
Diameter of drive cylinder	80 / 45 mm
Diesel engine	3-cylinder, 34.5 kW
Hopper capacity	360 l
Chassis (braked)	T-chassis 2,500 kg
Weight (full tank)	2,320 kg
Drawbar load	70 kg
Dimensions (L × W × H)	4,644 × 1,560 × 1,790 mm
Fill height	1,180 mm
Maximum grain size	32 mm
Pressure connection	5.5"

\*The data is based on empirical values and depends on the materials used

The P 718 is operated entirely from one side:

- infinitely variable adjustment of the delivery rate and engine speed, etc.

From here, you always have the material flow from the truck mixer in view. A robust plastic flap protects the operating elements and control displays from dirt and damage.



## Fine concrete and liquid screed

The P 718 conveys more than just fine concrete up to 32 mm. You can also use the piston pump for liquid screed.

This makes the P 718 an unbelievably versatile fine concrete pump that can be used when space is limited on the construction site.



The P 718 conveys fine concrete up to a grain size of 32 mm, among other things.



Truck mixers have ideal access to the large hopper.

# technology with the S transfer tube

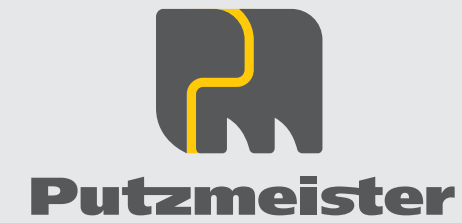

# Standard equipment and accessories

## Robust and reliable technology

The entire system of the P 718 is designed to work reliably even under heavy, constant usage. When selecting the components, we therefore made sure that **extremely robust and long-life parts** that meet our high quality standards were used:

- The powerful piston pump has hard-chrome plated cylinders, for example.
- The self-adjusting ring seals automatically and thus compensates for wear without the need for alteration
- The spectacle wear plate at the transition from the hopper to the delivery cylinder is also made of tempered steel
- Wear is also reduced by the flow-optimised design of the large S transfer tube...



## Highest availability based on long service intervals



The **agitator is positioned low down and is driven from both sides. It maintains a homogeneous mixture** and conveys the fine concrete directly to the cylinder openings without sucking in air. This produces a high fill level, a continuous material flow and a high delivery rate.

A vibrator is attached to the folding safety grille on the **hopper**. It ensures continuous material flow. The **large hopper can hold 360 l** and is designed to pump until almost empty. The remaining amount can be easily and conveniently emptied using the flap in the floor when cleaning.

## The heart of the P 718: the core pump

For years, Putzmeister products with their core pumps have been setting world records in pumping over long distances and to great heights. The trusted and extremely robust technology works reliably in continuous operation even with difficult material.

### Moreover, all wear parts can be replaced very easily:

- Replacement of the delivery pistons is achieved conveniently via the easily accessible water box.

- Hydraulics and switch cylinders do not come into contact with the material and therefore remain clean.
- The attachable hopper is easy to fold away when carrying out cleaning or servicing work.

The Putzmeister S transfer tube is designed for a particularly long service life and long service intervals.

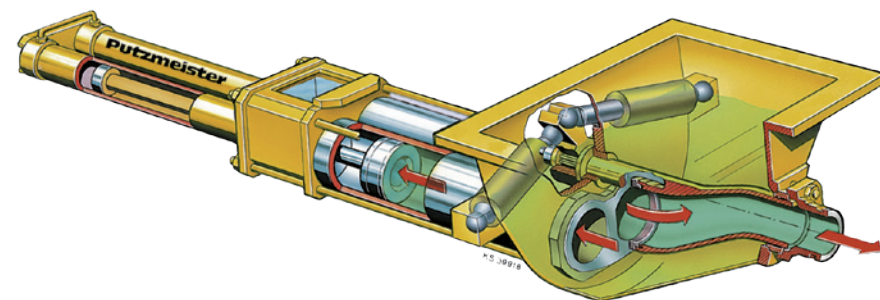

## Standard equipment for the P 718

Vibrator, rubber collar attachment, cleaning accessories, lifting eye, hard hat (yellow), toolbox with tools, operating manual and spare parts list.

## Optional accessories for the P 718

Couplings/ seals		Cleaning accessories	
Clamp coupling SK 5.5"	417 249	Delivery pipe elbow 90°	421 329
Clamp coupling SK 4.5"	431 613	Delivery pipe elbow 45°	057 593.007
A seal, SK 5,5" single-piece	055 559.001	Reduction pipe	
Seal, SK 4.5"	057 341.600	SK 5.5"/ SK 4.5", 1 m	057 604.006
Securing cotter pin	018 878.004		
Delivery line, SK 5.5", ID 125			
Delivery pipe, 1 m	056 849.008	■ <b>Cleaning accessories</b>	
Delivery pipe, 2 m	056 850.000	Sponge balls	
Delivery pipe, 3 m	056 851.009	medium, D 150 for SK 5.5"	018 841.002
Delivery pipe elbow 30° HP	258 935.008	hard, D 150 for SK 5.5"	223 673.007
Delivery pipe elbow 90° HP	261 402.007	D 120 for SK 4.5"	016 091.003
Delivery hose, 3 m	433 497	Wash-out adaptor	057 617.006
		Closing lid	057 619.004
Delivery line, SK 4.5", ID 100			
Delivery pipe, 1 m	056 861.002	■ <b>Rotary distributors</b>	
Delivery pipe, 2 m	056 862.001	RV0, SK 5.5", ID 125	500 570
Delivery pipe, 3 m	056 863.000	RV7, SK 5.5", ID 125	455 597
		RV10, SK 5.5", ID 125	426 078
		Additional information on request.	

## Complete fine concrete delivery line approx. 100 m (NW125/5.5", 85 bar, ≤ 32 mm grain size)

Flexible line:		Rigid line:		Additional accessories:	
46x clamp coupling	417 249	60x clamp coupling	417 249	Closing lid	
46x seal	055 559.001	60x seal	055 559.001	for T delivery pipe	057 628.008
46x securing cotter pin	018 878.004	60x securing cotter pin	018 878.004	Sponge balls	
4x delivery line elbow, 90°	261 402.007	6x delivery line elbow, 90°	261 402.007	6x medium, D 150	018 841.002
1x T delivery pipe, 1 m	057 615.008	2x delivery line elbow, 45°	057 596.004	6x hard, D 150	223 673.007
1x pressure gauge, 100 bar	521 448	2x delivery line elbow, 30°	258 935.008		
5x delivery hose, 2 m	027 643.000	1x T delivery pipe, 1 m	057 615.008	■ <b>Additional accessories:</b>	
18x delivery hose, 5 m	057 612.001	1x pressure manometer, 100 bar	521 448	Pipe clamp for wall/floor	053 800.008
2x end hose, 3 m	233 649.005	2x delivery pipe, 1 m	056 849.008	Manual gate valve GVM 2/2	
2x holder for end hose	054 371.002	2x delivery pipe, 2 m	056 850.000	SK 5.5", ID 125	413 087
Sponge balls		32x delivery pipe, 3 m	056 851.009	PM grout	266 743.004
6x medium, D 150	018 841.002	2x end hose, 3 m	233 649.005		
6x hard, D 150	223 673.007	2x holder for end hose	054 371.002		

# Fine concrete pump P 718

## Putzmeister Concrete Pumps GmbH

Max-Eyth-Straße 10 · 72631 Aichtal · Germany  
 P.O.Box 2152 · D-72629 Aichtal · Germany  
 Phone +49 71 27 599-0 · Fax +49 71 27 599-743  
 www.pmmortar.com · mm@putzmeister.de

